



# Honing Solution



## Honing Tools for Engine Remanufacturing

Intending to attend the market of engine remanufacturing, Brunitec developed a project focused exclusively on this segment. Through a research to find out the real problems in the process of remanufacturing engines of motorcycles, cars and trucks, we have designed the "BRUNIMAX" tool line. These tools have four brackets with super abrasive stones, as well as all the technology and facilities of the engine's manufacturers honing tools, at an affordable price on the market.

The main benefits of this line of tools are:

- Great cost-benefit.
- Compatible with any honing machine on the market.
- Provide high material removal and easy adjustment of the honing operation.
- Correct easily dimensional problems.
- They leave the product with the specified degree of finish (roughness).
- Increased rigidity and service life.
- Fine control adjustment of the measure through expander screw.
- It corrects possible misalignment of the tool in relation to the product to be honed.
- Economy of approximately 70% in consumption of honing oil.

If you need different tools from this standard line, please consult us.

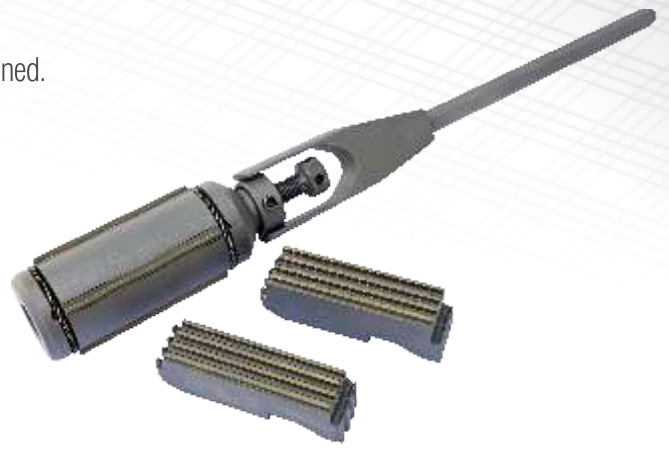

Model	Expansion capacity	Accessories
BRUNIMAX 1	ø 49 to 76 mm	Shoes 1A - ø 49 A 58 mm
		Shoes 1B - ø 58 A 67 mm
		Shoes 1C - ø 67 A 76 mm

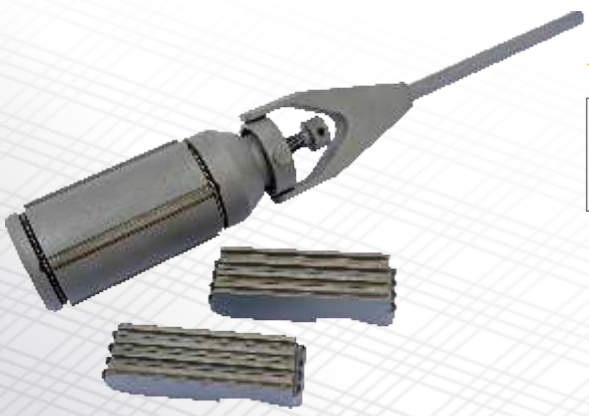

Model	Expansion capacity	Accessories
BRUNIMAX 2	ø 67 to 102 mm	Shoes 2A - ø 67 A 78,5 mm
		Shoes 2B - ø 78,5 A 90 mm
		Shoes 2C - ø 90 A 102 mm

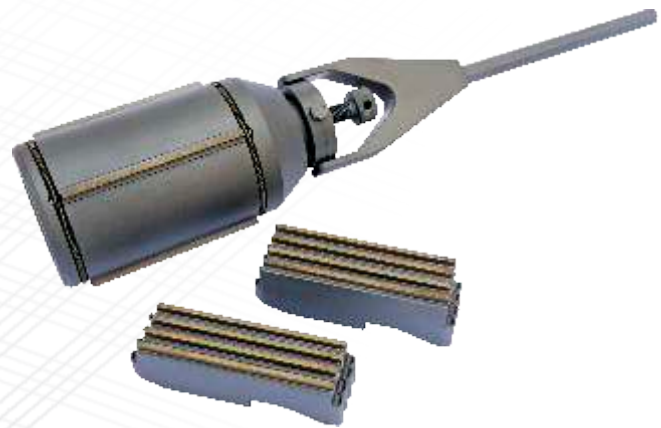

Model	Expansion capacity	Accessories
BRUNIMAX 3	ø 88 to 130 mm	Shoes 3A - ø 88 A 102 mm
		Shoes 3B - ø 102 A 116 mm
		Shoes 3C - ø 116 A 130 mm



We are a Brazilian company, founded in 1992, and we operate in the market offering innovative solutions in the field of honing machines, honing tools and diamond and Borazon honing stones. We have ISO 9001 certification and have exported our technology to many countries since 2003.

## Super Abrasives

Our range of super abrasives and honing tools offers to our customers a complete, competitive priced solution and technology developed to work in a wide range of materials including cast iron, tempered steel, forged steel, bronze, chrome, ceramics, among many others, covering all segments of the industry. We have a team of highly skilled and experienced engineers, technicians and designers, with one agile and flexible production, which makes our deadlines far below from our competitors.

We work on our super abrasive stones with the highest technology in metal alloys, diamonds and CBN (Cubic Boron Nitride), always using raw materials from the best suppliers in the world. With rigorously tracked and controlled manufacturing processes, the sintering of our abrasive stones are done in CNC machines with controlled atmosphere, ensuring that our products are consistent over time and are always delivered with the best quality for customers.

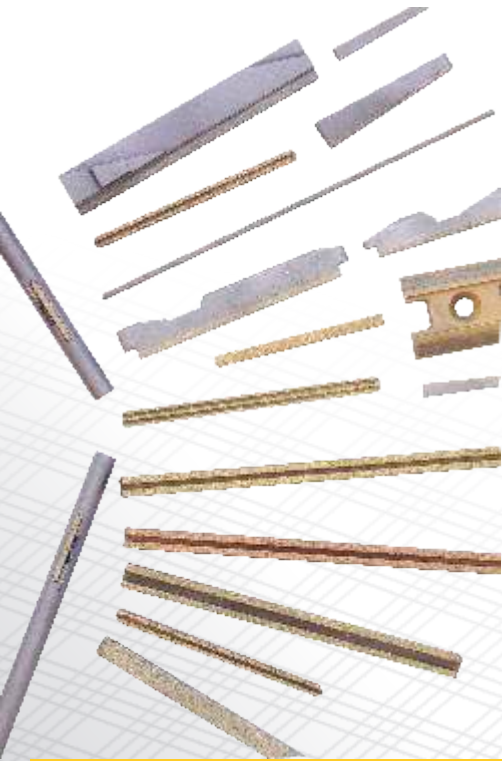

Estados Unidos street - N° 1250  
13324-220 - Salto - SP - Brasil  
Sales Phone + 55 11 4028-9942 - PABX + 55 11 4028-9944  
[ventas@brunitec.com.br](mailto:ventas@brunitec.com.br)

**BRUNITEC**  
Honing Solution

[www.brunitec.com.br](http://www.brunitec.com.br)

ISO 9001  
BUREAU VERITAS  
Certification



We have ISO 9001 certificate